

TEAC FD-05HGS-750
MICRO FLOPPY DISK DRIVE
HARDWARE SPECIFICATION

1. GENERAL

This is the hardware specification of the TEAC FD-05HGS, 3.5" double-sided 135-tpi micro floppy disk drive (hereinafter referred to as SFD) with a data capacity of 2MB/1.6/1MB (3 modes) and a SCSI interface board (hereinafter referred to as FC-5).

For the specification of the software, refer to "FC-5-00 Software Specification".

The outline of this SFD is shown in Table 1-1.

Model name	FD-05HGS-750		
TEAC P/N	19307597-50		
ROM P/N	13703861-00		
Safety standard	UL, CSA & IEC950(CB)		
Operation modes	2MB mode, write/read	1.6MB mode, write/read	1MB mode, write/read
Disk used	High density (2HD)	High density (2HD)	Normal density (2DD)
Data transfer rate	500k bits/sec	500k bits/sec	250k bits/sec
Disk speed	300rpm	360rpm	300rpm
Track density	135tpi		
Required power	+5V single (4.75~5.25V)		
Front bezel & flap	Black		
Eject button	Black		
LED indicator color	Green		
Indicator lighting condition	DRIVE SELECT plus FDD ready state		
Signal interface	SCSI (Small Computer System Interface: ANSI standard X3.131-1986)		
Terminator	Provided (at factory), 220/330Ω ±5%, detachable		
Parity strap setting	ON (at factory), ON/OFF switchable		
SCSI ID setting	ID=0 (at factory), SCSI ID 0 to 7 switchable		
Logical Unit Number	LUN=0		
Internal data buffer capacity	31K bytes		
Other optical function	Not equipped		

(Table 1-1) Specification outline

TABLE OF CONTENTS

Title	Page
1. GENERAL	1
2. BASIC SPECIFICATIONS	2
3. SYSTEM CONFIGURATION	4
3.1 System Configuration	4
3.2 Connection to the Host System	5
4. DISK	6
5. PHYSICAL SPECIFICATIONS	7
5.1 Physical Specifications	7
5.2 Frame Grounding	9
5.3 Nameplate	10
6. FUNCTIONAL SPECIFICATIONS	11
6.1 2MB Mode Data Capacity	11
6.2 1.6MB Mode Data Capacity	11
6.3 1MB Mode Data Capacity	12
6.4 Disk Rotation Mechanism	12
6.5 Index Detection	13
6.6 Track Construction	13
6.7 Magnetic Head	14
6.8 Track Seek Mechanism	14
6.9 Others	14
7. ENVIRONMENTAL CONDITIONS	16
8. RELIABILITY	18
9. POWER INTERFACE	20
9.1 Required Power	20
9.2 Power Interface Connector and Cable	21
10. SIGNAL INTERFACE	23
10.1 Electrical Characteristics	23
10.2 Signal Interface Connector and Cable	25
10.3 Input and Output Signals	28
10.4 Phase Sequence	30
10.5 Interface Timing	32
10.6 Control Sequence	44
10.6.1 Initialized state when the power is switched on or reset	44

10.6.2	Current consumption profile	46
10.7	Setting the Mode of the SFD	47
10.8	Customer Selectable Straps	49
10.8.1	Straps setting on the FC-5 board	49

This SFD uses two disks and has three write and read modes with an unformatted data capacity of 2M bytes/1.6M bytes/1M bytes, and the interface with the host system is SCSI. This SFD has a switch for the detection of the high-density identification hole (HD hole) in the disk cartridge, and can identify the type of cartridge now loaded in the SFD.

2. BASIC SPECIFICATIONS

(1) Signal interface : Pursuant to the ANSI standard X3.131-1986

(2) System configuration: Multiple initiators connectable

(3) Reselection : Available (LEVEL 2 compatible)

(4) Electrical characteristics:

Single-end driver/receiver

(5) Effective commands

TEST UNIT READY	RESERVE UNIT
REZERO UNIT	RELEASE UNIT
REQUEST SENSE	MODE SENSE
FORMAT UNIT	START/STOP UNIT
FORMAT TRACK	SEND DIAGNOSTIC
READ	READ CAPACITY
WRITE .	READ EXTEND
SEEK	WRITE EXTEND
INQUIRY	SEEK EXTEND
MODE SELECT	VERIFY
WRITE AND VERIFY	

(6) Terminator power

Provided with TERMPWR terminal to supply the interface with TERMPWR.

(7) SCSI ID ADDRESS

Setting 0 through 7 possible with the straps on the board. This is set to 0 at factory.

(8) Parity check

While parity check is always performed on output data from the SFD, whether the check to be done or not on input data can be selected with a strap on the board.

(9) Data transfer capacity: 640k bytes/sec (Asynchronous transfer)

However, this value is the average transfer speed in the case the host system responds in the shortest time.

3. SYSTEM CONFIGURATION

3.1 System Configuration

The following system configurations are available with the SCSI interface unit. When more than one SCSI device is connected, it is necessary to remove termination resistors except for that at the terminating SCSI device.

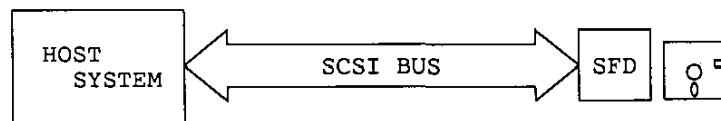

SINGLE INITIATOR, SINGLE TARGET

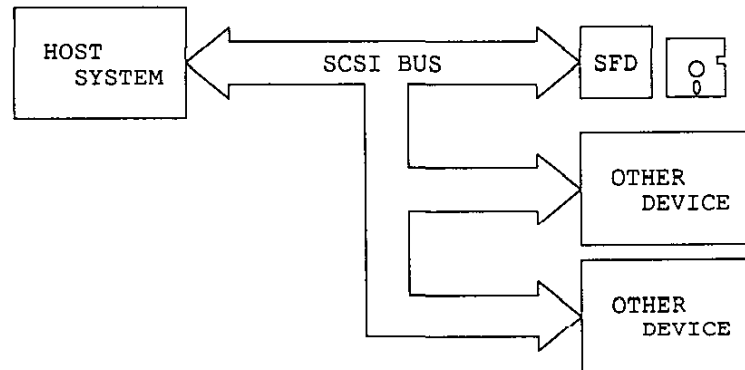

SINGLE INITIATOR, MULTI TARGET

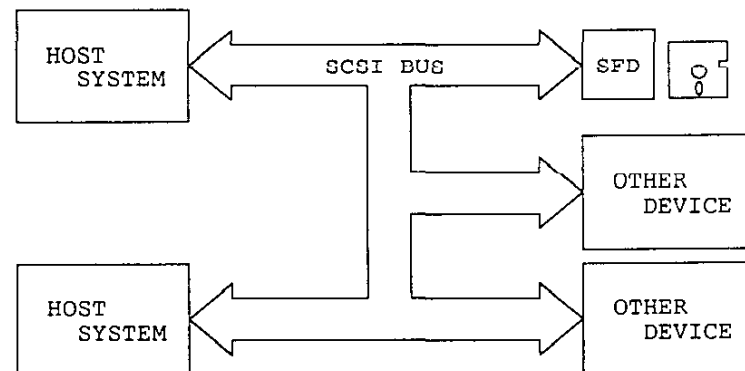

MULTI INITIATOR, MULTI TARGET

(Fig.3-1) System configuration

3.2 Connection to the Host System

The SFD is either incorporated into the host system of the Work Station, IBM-PC-AT, IBM-PS/2, etc. to connect an independent SCSI device or used as part of a subsystem as shown below.

- (1) When incorporating the SFD into the host system using daisychain connection, it is necessary to use an interface cable, the middle part of which is connected to the interface connector. (Refer to Fig.3-2)

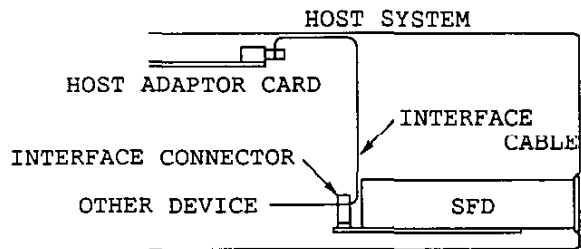

(Fig.3-2) Daisychain connection within the host system

- (2) When constructing a subsystem, run the cable from the drive connector as shown in Fig.3-3, then install two sets of connectors onto the back panel of the subsystem. It is desirable that both of the two connectors are connected.

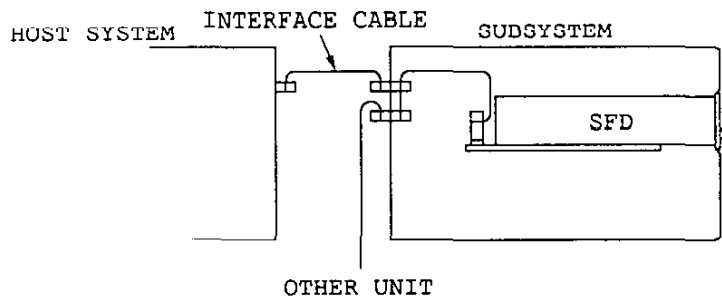

(Fig.3-3) Daisychain connection when incorporated into subsystem

* IBM-PC-AT and IBM-PS/2 are trademarks of International Business Machines Corporation.

In each case, the total length of the interface cable(s) used shall not exceed 6m.

When the interface cable extends out of the system, use shielded cables and connectors which shall protect the signals from radiation noise.

4. DISK

3.5" micro floppy disks on Table 4-1 which are mutually agreed between the customer and TEAC.

Operation mode	Disk type	Magnetic powder	Magnetizing method
1MB	Normal density (DD)	Co- γ -Fe ₂ O ₃	Surface recording
1.6MB	High density (HD)	Co- γ -Fe ₂ O ₃	Surface recording
2MB	High density (HD)	Co- γ -Fe ₂ O ₃	Surface recording

(Table 4-1) Disk used

5. PHYSICAL SPECIFICATIONS

5.1 Physical Specifications

- (1) Width : 101.6mm (4.00 in), Max.
 - (2) Height : 25.4mm (1.00 in), Nom.
 - (3) Depth : 144.5mm (5.69 in), Nom. (excluding front bezel)
 - (4) Weight : 246g (0.542 lbs), Nom., 260g (0.573 lbs), Max.
 - (5) External view : See Fig.5-1
 - (6) Cooling : Natural air cooling
 - (7) Direction of installation: As described below.
 - (a) The disk may be inserted vertically from the front.
 - (b) The disk may be inserted horizontally from the front. However, the orientation with the PC board positioned on the upper side is not permitted.
 - (c) In case of (a) and (b), the front flap side can be tilted to upward maximum 25 degrees.
- Note: As to the other mounting directions than the above will be considered separately.
- (8) Installation : With installation holes on the bottom side or the both sides of the SFD. Refer to Fig.5-1
 - (9) Material of frame (Base) : Aluminum diecast
Material of SCSI bracket : A galvanized sheet iron
 - (10) Material of front bezel : PPHOX

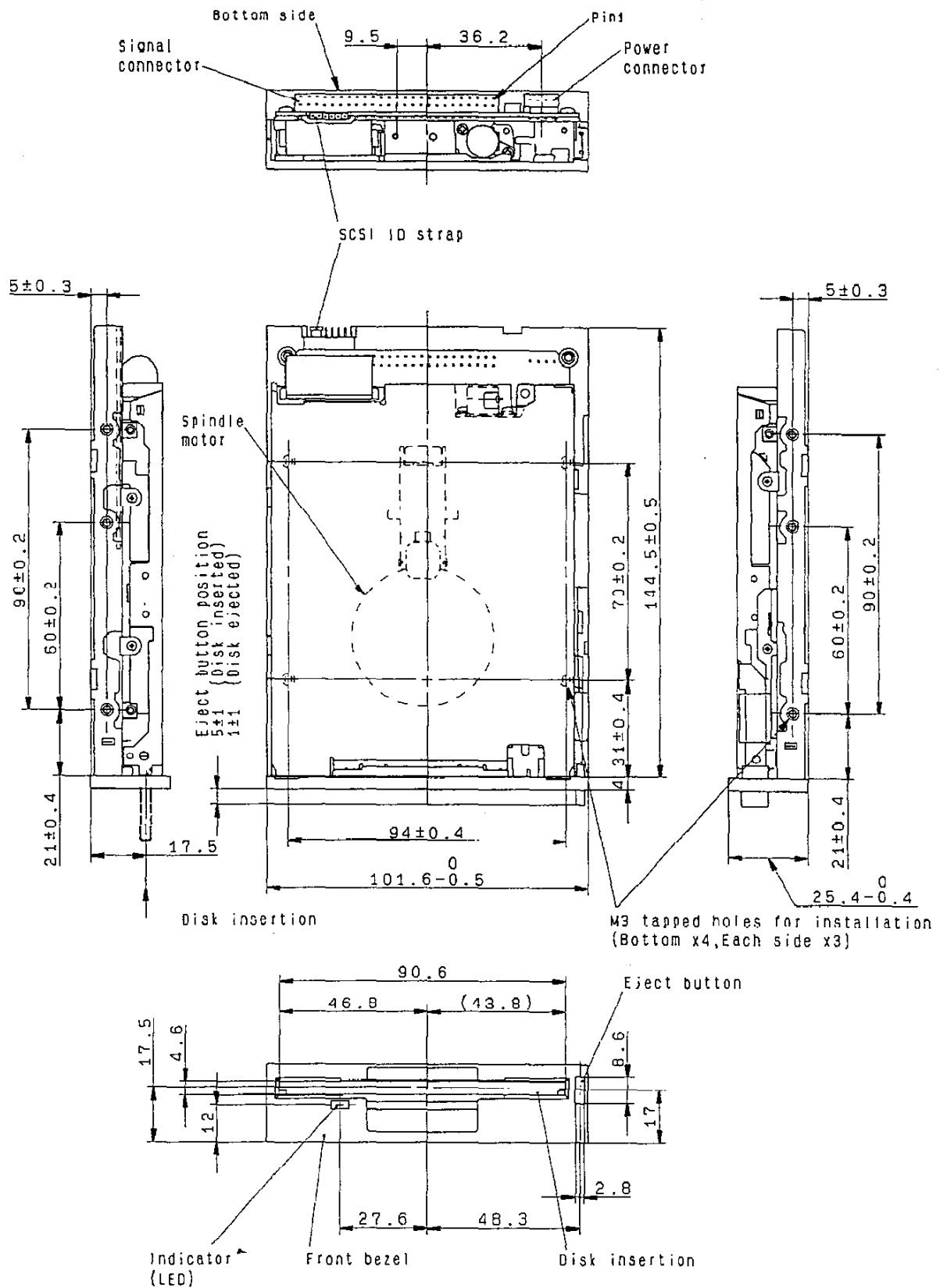

(Fig.5-1) External view

(Units:mm)

5.2 Frame Grounding

- (1) The SFD frame is electrically connected to DC 0V by a mounting screw on the PCB via chip jumper R2/9 on the main PCBA and chip jumper S10 on the FC-5 PCBA. (See Fig.5-2)

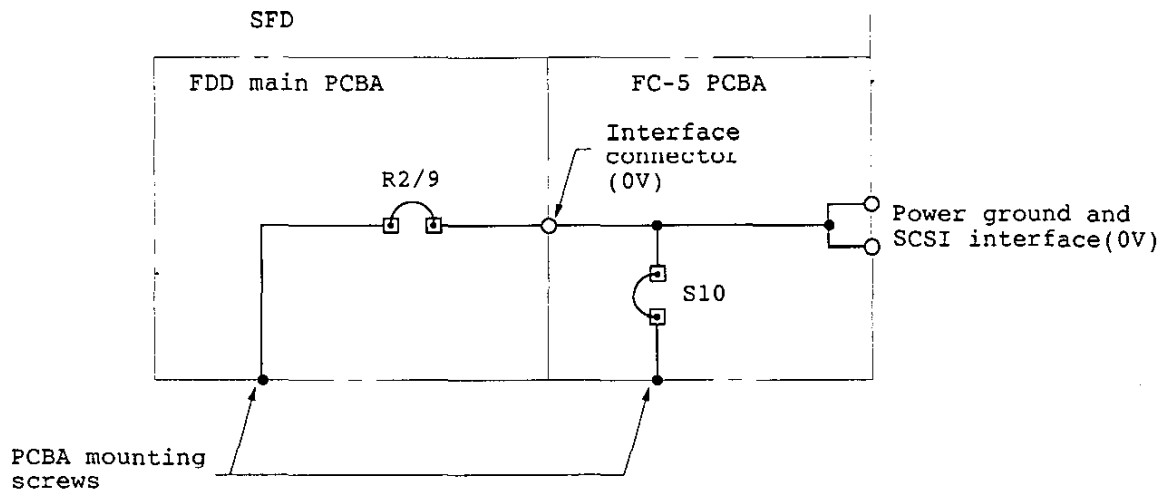

(Fig.5-2) Frame ground internal connection

5.3 Nameplate

The location where the nameplate is attached onto the SFD is shown in Fig. 5-3.

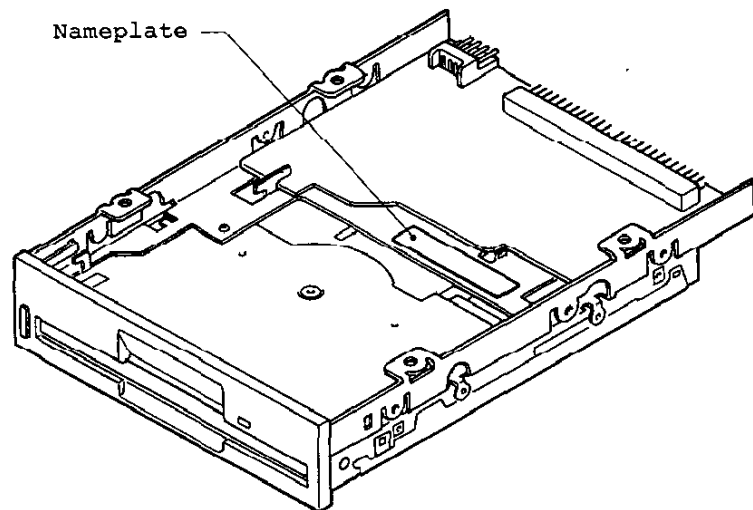

(Fig.5-3) Location where the nameplate is attached

6. FUNCTIONAL SPECIFICATIONS

6.1 2MB Mode Data Capacity

Recording method			FM	MFM
Data transfer rate between FC-5 - FDD (k bits/sec)			250	500
Tracks/disk			160	160
Innermost track bit density (bpi), Side 1			8,717	17,434
Innermost track flux density (frpi), Side 1			17,434	17,434
Data capacity	Unformatted	k bytes/track	6.25	12.50
		k bytes/disk	1,000	2,000
	32 sectors /track	k bytes/sector	0.128	0.256
		k bytes/track	4.096	8.192
		k bytes/disk	655.36	1,310.72
	18 sectors /track	k bytes/sector	0.256	0.512
		k bytes/track	4.608	9.216
		k bytes/disk	737.28	1,474.56
	10 sectors /track	k bytes/sector	0.512	1.024
		k bytes/track	5.12	10.24
		k bytes/disk	819.20	1,638.40

(Table 6-1) 2MB mode data capacity

6.2 1.6MB Mode Data Capacity

Recording method			FM	MFM
Data transfer rate between FC-5 - FDD (k bits/sec)			250	500
Tracks/disk			160	160
Innermost track bit density (bpi), Side 1			7,264	14,528
Innermost track flux density (frpi), Side 1			14,528	14,528
Data capacity	Unformatted	k bytes/track	5.208	10.416
		k bytes/disk	833.28	1,666.56
	26 sectors /track	k bytes/sector	0.128	0.256
		k bytes/track	3.328	6.656
		k bytes/disk	532.48	1,064.96
	15 sectors /track	k bytes/sector	0.256	0.512
		k bytes/track	3.840	7.680
		k bytes/disk	614.40	1,228.80
	8 sectors /track	k bytes/sector	0.512	1.024
		k bytes/track	4.096	8.192
		k bytes/disk	655.36	1,310.72

(Table 6-2) 1.6MB mode data capacity

6.3 1MB Mode Data Capacity

Recording method			FM	MFM	
Data transfer rate between FC-5 - FDD (k bits/sec)			125	250	
Tracks/disk			160	160	
Innermost track bit density (bpi), Side 1			4,359	8,717	
Innermost track flux density (frpi), Side 1			8,717	8,717	
Data capacity	Unformatted	k bytes/track	3.125	6.250	
		k bytes/disk	500	1,000	
	F o r m a t t e d	16 sectors /track	k bytes/sector	0.128	0.256
			k bytes/track	2.048	4.096
		9 sectors /track	k bytes/disk	327.68	655.36
			k bytes/sector	0.256	0.512
	5 sectors /track	k bytes/track	2.304	4.608	
		k bytes/disk	368.64	737.28	
		k bytes/sector	0.512	1.024	
			k bytes/track	2.560	5.120
			k bytes/disk	409.60	819.20

(Table 6-3) 1MB mode data capacity

6.4 Disk Rotation Mechanism

- (1) Spindle motor : Direct DC brushless motor
- (2) Spindle motor speed
 - 2MB/1MB mode : 300rpm
 - 1.6MB mode : 360rpm
- (3) Motor servo method : Frequency servo by ceramic oscillator
- (4) Motor/spindle connection: Motor shaft direct
- (5) Disk speed : The same as the spindle speed
 - Long term speed variation (LSV):
 - ±1.5% or less
 - Instantaneous speed variation (ISV):
 - ±3% or less

- (6) Start time : 500msec or less
- (7) Average latency, 360rpm : 83.3msec
300rpm : 100msec
- (8) Speed switching time : 480msec or less (300rpm \rightleftharpoons 360rpm)

6.5 Index Detection

- (1) Number of index : 1 per disk revolution
- (2) Detection method : Rotor revolution detection of the spindle motor by Hall IC
- (3) Detection cycle, 360rpm : 166.7msec \pm 1.5%
300rpm : 200msec \pm 1.5%
- (4) Index burst detection timing error (with specified test disk)
360rpm : 340 μ sec or less
300rpm : 400 μ sec or less

6.6 Track Construction

- (1) Track density (nominal): 135tpi (track pitch 187.5 μ m, nominal)
- (2) Number of cylinders : 80 cylinders
- (3) Number of tracks : 160 tracks/disk
- (4) Outermost track radius (track 00): Side 0 39.500mm (1.5551 in)
Side 1 38.000mm (1.4961 in)
Innermost track radius (track 79): Side 0 24.6875mm (0.9719 in)
Side 1 23.1875mm (0.9129 in)
- (5) Positioning accuracy: \pm 15 μ m or less, with specified test disk.
(Track 40, 23 \pm 2°C, 45 ~ 55% Rh)

6.7 Magnetic Head

- (1) Magnetic head: Read/write head with erase gap, 2 sets
- (2) Effective track width after trim erase:
0.115 ± 0.008mm (0.0045 ± 0.0003 in)
- (3) Read/write gap azimuth error: ±18' or less, with specified test disk

6.8 Track Seek Mechanism

- (1) Head positioning mechanism: Stepping motor with lead screw
- (2) Stepping motor : 4-phase, 20 steps per revolution
- (3) Stepping motor drive : 2 steps per track
- (4) Track 00 detection method : Photo-interrupter
- (5) Track to track time : 3msec
- (6) Settling time : 15msec or less (excludes track to track time)

6.9 Others

- (1) Recommended write precompensation (all tracks): 2MB/1MB mode
2MB mode : ±125nsec
1.6MB/1MB mode: 0 ~ ±125nsec
- (2) Head loading mechanism: Not equipped
(The FDD becomes head loading condition whenever a disk is installed)
- (3) File protect mechanism: Write-inhibit hole is detected by a mechanical switch.

- (4) Disk detection mechanism: Disk installation is detected by a mechanical switch
- (5) Disk inserting force: 700g or less at the center of the disk
- (6) Disk ejecting force: 1,200g or less
- (7) Acoustic noise (at a distance of 50cm):
45dBA or less (during a 3msec seek operation)
- (8) Disk type identification mechanism: HD hole detection using a mechanical switch.

7. ENVIRONMENTAL CONDITIONS

(1) Ambient temperature

- (a) Operating : 4 ~ 51.7°C (39 ~ 125°F)
- (b) Storage : -22 ~ 60°C (-8 ~ 140°F)
- (c) Transportation: -40 ~ 65°C (-40 ~ 149°F)

(2) Temperature gradient

- (a) Operating : 20°C (27°F) hour or less (non-condensing)
- (b) Storage and transportation:
30°C (54°F) hour or less (non-condensing)

(3) Relative humidity

- (a) Operating : 20 ~ 80% (non-condensing)
Maximum wet bulb temperature; 29.4°C (85°F)
- (b) Storage : 5 ~ 90% (non-condensing)
Maximum wet bulb temperature; 40°C (104°F)
- (c) Transportation: 5 ~ 95% (non-condensing)
Maximum wet bulb temperature; 45°C (113°F)

(4) Vibration

- (a) Operating : 1.5G or less (10 ~ 100Hz, 1oct/min. sweep rate)
0.5G or less (100 ~ 200Hz, 1oct/min. sweep rate)
0.25G or less (200 ~ 600Hz, 1oct/min. sweep rate)
- (b) Transportation: 2G or less (10 ~ 100Hz, 1/4oct/min. sweep rate)

(5) Shock

- (a) Operating
Write & read : 5G (11msec, 1/2 sine wave) or less
Read only : 10G (11msec, 1/2 sine wave) or less
Soft errors are allowed if they are recoverable within
16 retries.
- (b) Transportation: 70G (11msec, 1/2 sine wave) or less
(single shock)

(6) Altitude (operating): -300m (-980 feet) ~ 5,000m (16,400 feet)

Note: The above requirements are applied for the SFD without shipping box.
When a long period is required for transportation such as by ship,
storage environmental conditions should be applied.

8. RELIABILITY

- (1) MTBF: 30,000 power on hours or more (for typical usage)
- (2) MTTR: 30 minutes or less
- (3) Design component life: 5 years
- (4) Disk life: 3×10^6 passes/track or more
- (5) Disk insertion: 1.5×10^4 times or more
- (6) Seek operation life: 1×10^7 random seeks or more
- (7) Preventive maintenance: Not required (for typical usage)
- (8) Error rate
 - (a) Soft read error: 1 or less per 10^9 bits read
(In the event of error, retry is performed up to 16 times automatically, including three recalibrations to track 00)
 - (b) Hard read error: 1 or less per 10^{12} bits read
(In the event of error, retry is performed up to 16 times automatically, including three recalibrations to track 00)
 - (c) Seek error : 1 or less per 10^6 seeks
(In the event of error, retry is performed up to 16 times automatically, including three recalibrations to track 00)
- (9) Safety standard: Approved by UL, CSA and IEC950(CB)
- (10) Static withstand voltage: When a static voltage of 10kV (150pF, 330 Ω) is applied to the operator accessible area in testing the SFD, the data written to the disk,

components in the SFD, and function of the SCSI bus should be free from damage.

9. POWER INTERFACE

9.1 Required Power

The following specifications are applied at power interface connector of the SFD. Power is fed to the FDD via the signal interface FFC cable (1, 3, and 5 pins) between FC-5 and FDD.

(1) DC +12V: Not required

(2) DC +5V

(a) Voltage tolerance: $\pm 5\%$ (4.75 ~ 5.25V)

(b) Allowable ripple voltage: 100mVp-p or less (including spike noise)

(c) Current and power consumption

Operating mode	Average current		Average power	
	Typ.	Max.	Typ.	Max.
Stand-by *1	60mA	80mA	0.3W	0.4W
Read Operation *1	0.29A	0.41A	1.45W	2.15W
Write Operation *1	0.29A	0.41A	1.45W	2.15W
Seek Operation *1	0.54A	0.66A	2.70W	3.47W
Motor start *1	0.70A	0.78A	3.50W	4.10W
Terminator current *2	0.16A	0.30A	0.80W	1.58W

- Notes: 1. Values of Typ. current and power are specified at 5.0V, while the values of Max. are at 5.25V (+5%) with a disk of large running torque.
2. The stand-by mode refers to when the SCSI bus is in the BUS FREE phase and when the spindle motor and seek stop.
3. The maximum current consumption period while the spindle motor is operating is within 150msec.
4. Maximum short-period peak current except for the surge current when power is switched on is 1.3A or less.
5. For the example of current consumption time chart, refer to 10.6.2.
6. The current values of items marked *1 indicate those without the terminator. The current values with the terminator will be those to which terminator current values marked *2 are added.

(Table 9-1) Current and power consumption

(3) Power rise time, fall time: Arbitrary

9.2 Power Interface Connector and Cable

(1) Power interface connector

(a) SFD side connector: IRISO Electronics Co., LTD. P/N IMSA-6056B-04C
(natural color) or equivalent

(b) Pin numbers: 4 pins

(c) Protection method for mis-connection:

Mechanical protection by the shape of connector housing.

(d) Connector external view: See Fig.9-1

(e) Connector location: See Fig.5-1

(f) Power interface pin-assignment: See Table 9-2

(g) Cable side matched connector: AMP, P/N 171822-4 (natural color)
or equivalent

matched pin: AMP, P/N 170204-2 (AWG #20 ~ 26, loose
piece) or P/N 170262-2 (AWG #20 ~ 26,
strip form) or equivalent

(2) Power interface cable

Any appropriate cables will be acceptable as long as the maximum power consumption of the SFD and voltage at the power connector are taken into consideration.

Power voltage	Pin numbers
DC +5V	1
0V	2
(0V)	3
(No connection)	4

(Table 9-2) Power interface pin-assignment

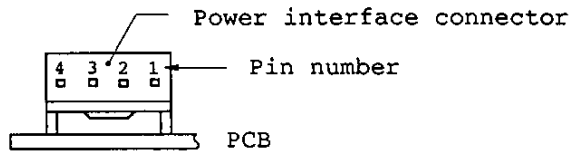

Rear view

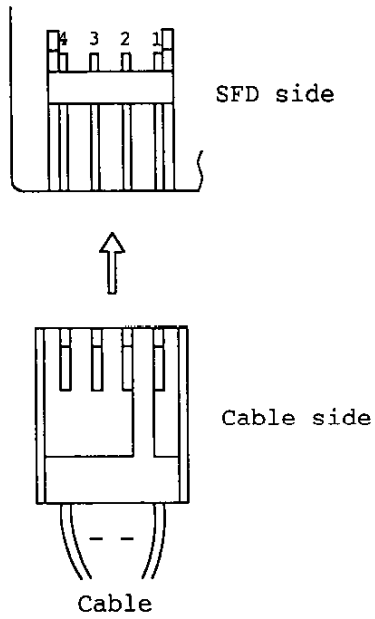

Top view

(Fig.9-1) Power interface connector external view

10. SIGNAL INTERFACE

10.1 Electrical Characteristics

Notes: 1. The specifications in items (2) are applicable at the SCSI connector.

2. Vcc indicates the +5V supply voltage to be fed to the SFD.

(1) I/O circuit: See Fig.10-1 ~ 10-3

(2) Electrical characteristics of I/O circuit

(a) Input signal level

logic "1" (TRUE) : 0 ~ 0.8V

logic "0" (FALSE): 2.0 ~ 5.25V

Hysteresis width : 0.2V, Min

(b) Output signal level

logic "1" (TRUE) : 0 ~ 0.4V

logic "0" (FALSE): 2.5 ~ 5.25V

(c) Maximum load current of receiver: -0.2mA (excl. terminator current)

(d) Output driver sink current: 48mA (low level voltage: 0.4V)

(e) Terminator: 220 Ω \pm 5% (at DC +5V side)

330 Ω \pm 5% (at 0V side)

(Terminator is detachable)

(f) TERMPWR output signal

Output voltage: 4.2 ~ 5.25V

Maximum output current: 1.0A

Output current limitation: Fuse (1.0A)

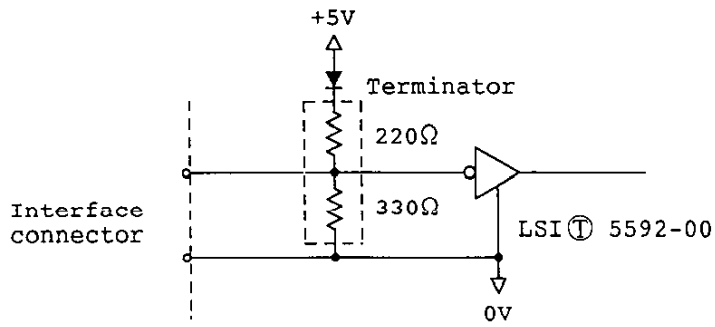

(Fig.10-1) Input circuit

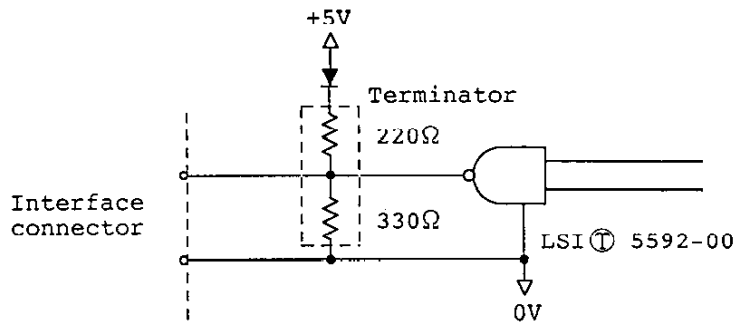

(Fig.10-2) Output circuit

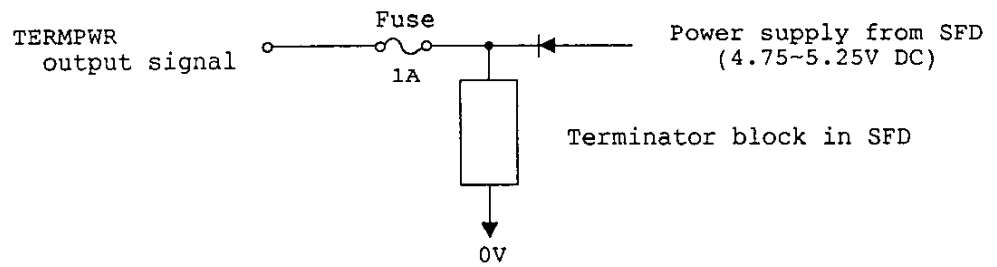

(Fig.10-3) TERMPWR output circuit

10.2 Signal Interface Connector and Cable

(1) Signal interface connector

- (a) SFD side connector: IRISO Electronics Co., LTD. P/N IMSA-9022B-49Z53-GT or equivalent
- (b) Pin numbers and pin pitch: 2 rows of 25 poles (50 poles), 2.54mm (0.1 in) pitch.
- (c) Interface connect or pin-assignment: See Table 10-1
- (d) Cable side matched connector: Fujitsu, P/N FCN-707J050-AU/0 or equivalent.
- (e) Cable side mis-insertion protection key:
Fujitsu FCN-700A1 or equivalent
- (f) Connector location: See Fig.5-1

(2) Signal interface cable

- (a) Applicable cable: Sumitomo 3M, P/N 3365-50 or equivalent
- (b) Maximum cable length: 6m (20 feet)

Pin No.		Signal name	Symbol	Signal direction
GND	DATA			
1	2	DATA BUS 0 (LSB)	-DB0	HOST ↔ FC-5
3	4	DATA BUS 1	-DB1	↔
5	6	DATA BUS 2	-DB2	↔
7	8	DATA BUS 3	-DB3	↔
9	10	DATA BUS 4	-DB4	↔
11	12	DATA BUS 5	-DB5	↔
13	14	DATA BUS 6	-DB6	↔
15	16	DATA BUS 7 (MSB)	-DB7	↔
17	18	DATA BUS PARITY	-DBP	↔
19	20	GND	GND	
21	22	GND	GND	
23	24	RESERVED	RES	
25(P.KEY)*	26	TERMINATOR POWER	TERMPWR	HOST ↔ FC-5
27	28	RESERVED	RES	
29	30	GND	GND	
31	32	ATTENTION	-ATN	HOST → FC-5
33	34	GND	GND	
35	36	BUSY	-BSY	HOST ↔ FC-5
37	38	ACKNOWLEDGE	-ACK	→
39	40	RESET	-RST	→
41	42	MESSAGE	-MSG	←
43	44	SELECT	-SEL	↔
45	46	CONTROL/DATA	-C/D	←
47	48	REQUEST	-REQ	←
49	50	INPUT/OUTPUT	-I/O	←

Notes: 1. Signals are all true at low level.

2. Terminals with odd numbers are all GND except for terminal No.25 (remove the pin to protect mis-insertion), No.23 and No.27 (Reserved).

(Table 10-1) Interface connector pin-assignment table

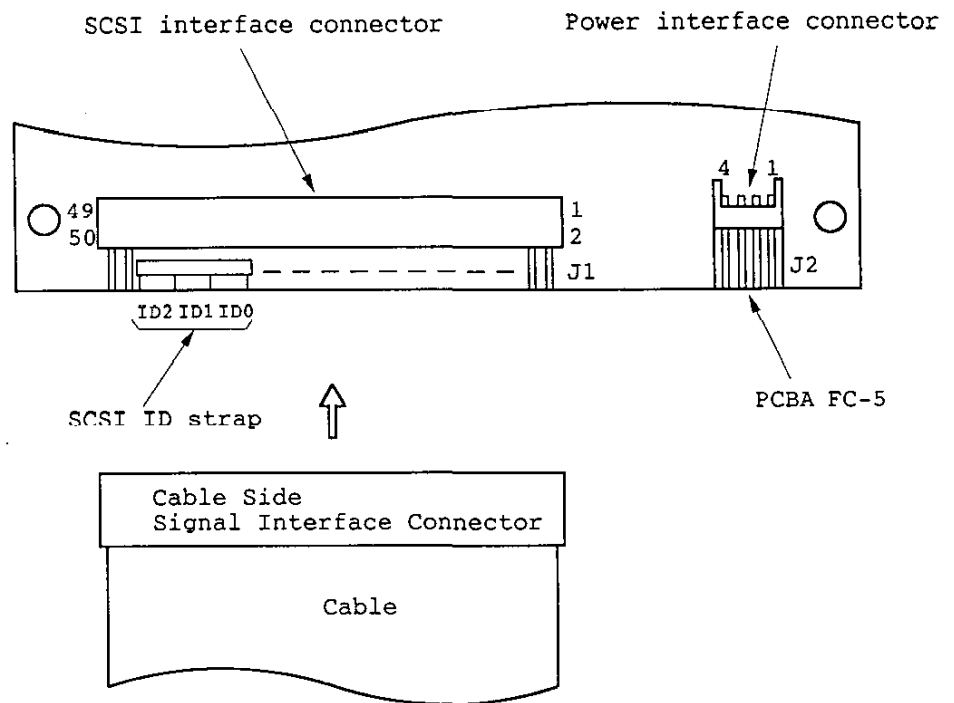

(Fig.10-5) Signal interface connector external view

10.3 Input and Output Signals

For the signals indicated below, an input signal represents a signal transmitted to FC-5 and an output signal, a signal transmitted from FC-5. Input/output signal represents a bidirectional signal. All the signals are true at low level.

(1) BUSY (-BSY): input/output signal

This signal is used in the following three ways.

- (a) This signal goes true when the SCSI interface bus is in use.
- (b) If the FC-5 attempts to gain control of the SCSI bus in the ARBITRATION phase, this signal goes true.
- (c) This signal is a response signal to the -SEL signal from the host system or the SFD in the SELECTION phase and RESELECTION phase.

(2) SELECT (-SEL): input/output signal

This is to select one out of the devices on the interface bus. The selected device responds with its -BSY signal turned to true. Device address information is delivered to -DB0 ~ -DB7 together with this signal.

(3) CONTROL/DATA (-C/D): output signal

Indicates the type of information to be transferred through -DB0 ~ -DB7. Control information is transferred when this signal is true and data information when it is false.

(4) INPUT/OUTPUT (-I/O): output signal

Indicates direction of the information transferred through -DB0 ~ -DB7. Transfer takes place from FC-5 to the host system when this signal is true and from the host system to FC-5 when it is false.

(5) MESSAGE (-MSG): output signal

This signal is turned to true in the MESSAGE phase where information is exchanged between the host system and FC-5. The direction of message transfer is indicated by the -I/O signal.

- (6) REQUEST (-REQ): output signal
Controls transfer timing at which the information is transferred through -DB0 ~ -DB7 (for handshake control) and is a data transfer request signal.
- (7) ACKNOWLEDGE (-ACK): input signal
Controls transfer timing at which the information is transferred through -DB0 ~ -DB7 (for handshake control) and is a response signal to the -REQ signal.
- (8) ATTENTION (-ATN): input signal
Requests reception of a message sent from the host system. MESSAGE OUT phase is executed when FC-5 receives this signal.
- (9) RESET (-RST): input signal
Restores the initial state of FC-5. This signal must have a $25\mu\text{s}$ or more pulse width. Within 800ns after this signal becomes TRUE, the FC-5 enters BUS FREE phase. However, the response time (point ⑥ onward in Fig. 10-18) to the FC-5 initiator selection will be after the following operation is over and 1,100ms after this signal becomes TRUE.
- (a) While WRITE/READ-related commands are in execution, the duration lasts until the WRITE/READ processing of all blocks in the cylinder currently in execution is over.
- (b) The initial state operation of the FC-5 after (a) is over.
- Therefore, if the total number of blocks in the cylinder are exceeded in WRITE-related commands, or the blocks that overflow to the adjacent cylinder are specified and the RESET signal becomes true during processing, part of the data may not be processed.
- (10) DATA BUS 0-7 (-DB0 ~ -DB7): input/output signal
8-bit bidirectional bus for mutual transfer of control and data information. -DB7 is the MSB (Most Significant Bit) and -DB0 the LSB (Least Significant Bit).

(11) DATA BUS PARITY (-DBP): input/output signal

Parity signal for -DB0 ~ -DB7 signals. When information is sent from FC-5, it is set up as odd parity and output with the same timing as -DB0 ~ -DB7.

When FC-5 receives information, whether parity checking (odd parity) should be done or not can be selected by setting a switch in FC-5.

10.4 Phase Sequence

This interface consists of the following operation phases.

- (a) BUS FREE phase
- (b) ARBITRATION phase
- (c) SELECTION phase
- (d) RESELECTION phase
- (e) COMMAND phase
- (f) DATA phase
- (g) STATUS phase
- (h) MESSAGE phase

The phase sequences are shown in Fig.10-6. There are sequences with and without ARBITRATION. The commands for FC-5 are executed with the sequences shown in Fig.10-6, though DATA phase may not be available for some commands. Even for a command with data transfer, DATA phase may not be available or may be discontinued depending on error information.

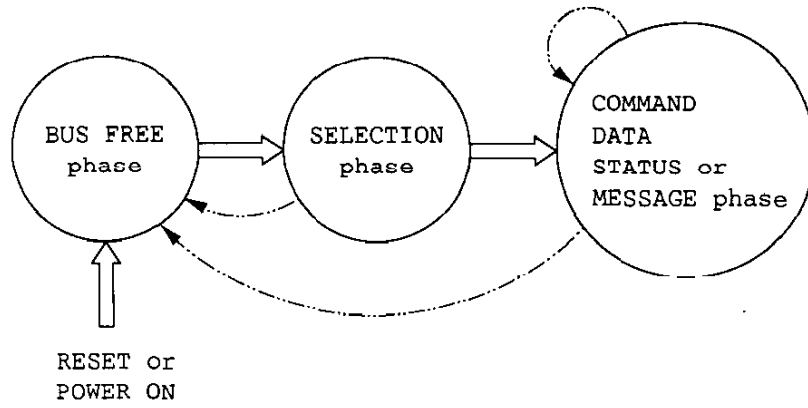

Host system without ARBITRATION

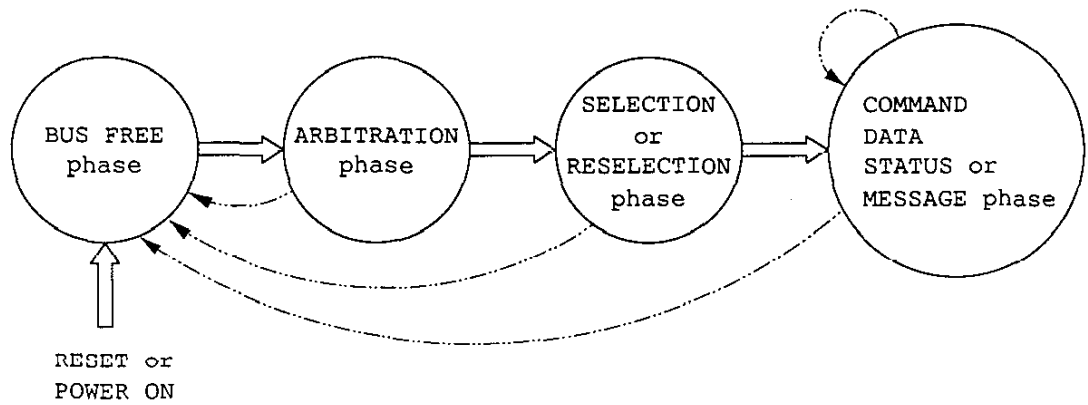

Host system with ARBITRATION

(Fig.10-6) Phase sequence

10.5 Interface Timing

The following specifications are all applied to the ends of the FC-5 interface connectors.

- (1) RESET timing : Fig.10-7
- (2) BUS FREE phase timing : Fig.10-8
- (3) ARBITRATION phase timing: Fig.10-9
- (4) SELECTION phase timing : Fig.10-10
- (5) RESELECTION phase timing: Fig.10-11
- (6) COMMAND phase timing : Fig.10-12
- (7) DATA IN phase timing : Fig.10-13
- (8) DATA OUT phase timing : Fig.10-14
- (9) STATUS phase timing : Fig.10-15
- (10) MESSAGE IN phase timing : Fig.10-16
- (11) MESSAGE OUT phase timing: Fig.10-17

In Fig.10-7 to Fig.10-17, 'H' denotes high level (logic '0' false) and 'L', low level (logic '1' true).

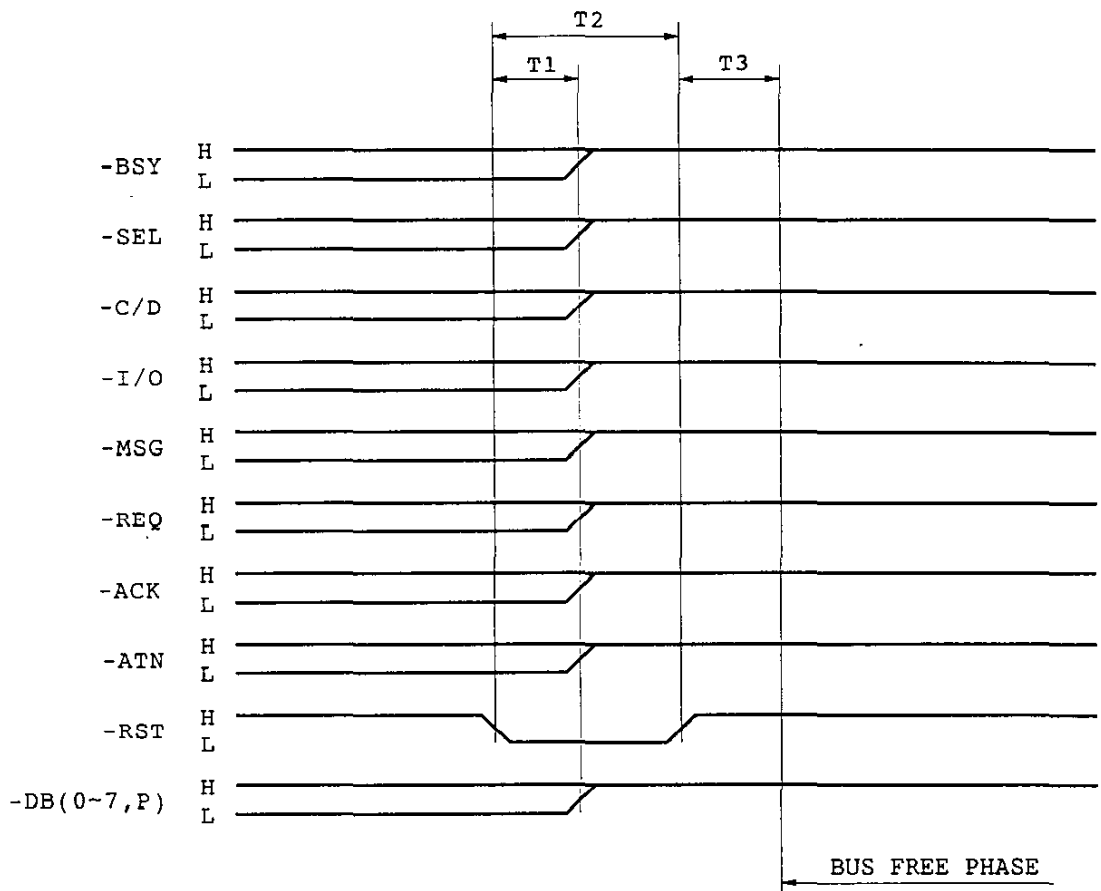

Symbol	Description of symbol	MIN.	TYP.	MAX.	Unit
T1	BUS CLEAR DELAY			800	ns
T2	RESET HOLD	25			μ c
T3	BUS SETTLE DELAY	400			ns

(Fig.10-7) RESET timing

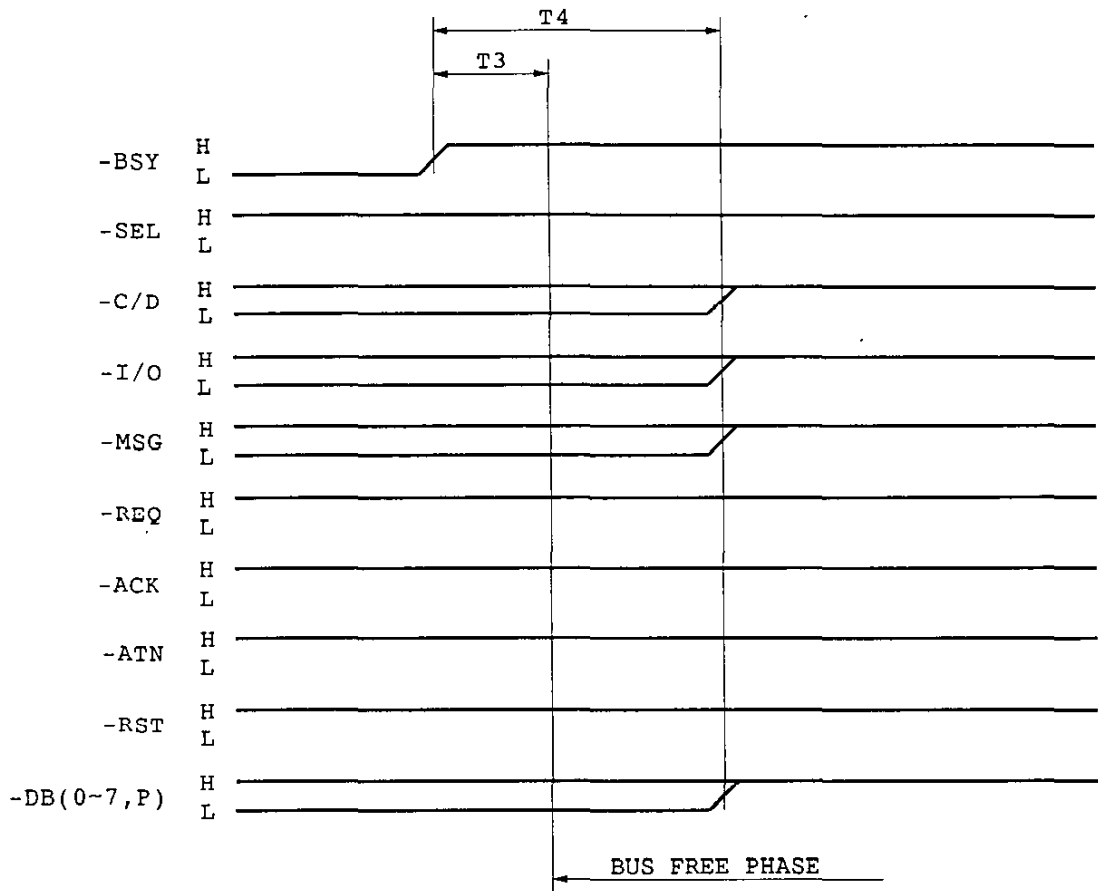

Symbol	Description of symbol	MIN.	TYP.	MAX.	Unit
T3	BUS SETTLE DELAY	400			ns
T4	T3 + BUS CLEAR DELAY			1.2	μs

(Fig.10-8) BUS FREE phase timing

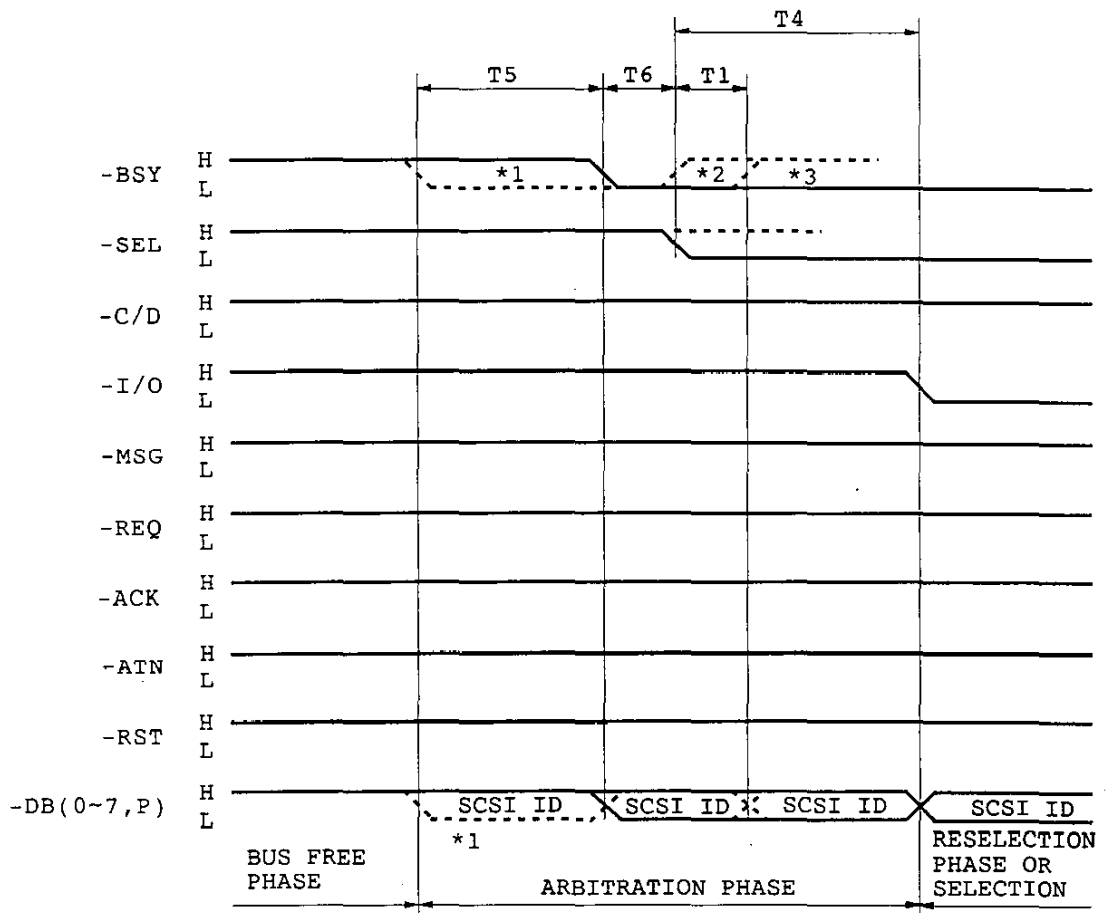

Symbol	Description of symbol	MIN.	TYP.	MAX.	Unit
T1	BUS CLEAR DELAY			800	ns
T4	BUS SETTLE + BUS CLEAR	1.2			μ s
T5	BUS FREE DELAY	800		1800	ns
T6	ARBITRATION DELAY	2.2			μ s

- Notes:
1. Broken line *1 indicates the case in which a -BSY signal from another SCSI device, and the ID bit of that device have already been asserted on the data bus.
 2. Broken line *2 indicates the case in which an ID bit with higher order than this SFD ID is sent to the data bus. The SFD releases the data bus at the same time.
 3. T1 and the broken line *3 indicate the case in which the SEL signal has been asserted from another SCSI device before this FC-5 checks -DB0~7 in the ARBITRATION phase. In this case, the FC-5 releases the data bus at the same time.

(Fig.10-9) ARBITRATION phase timing

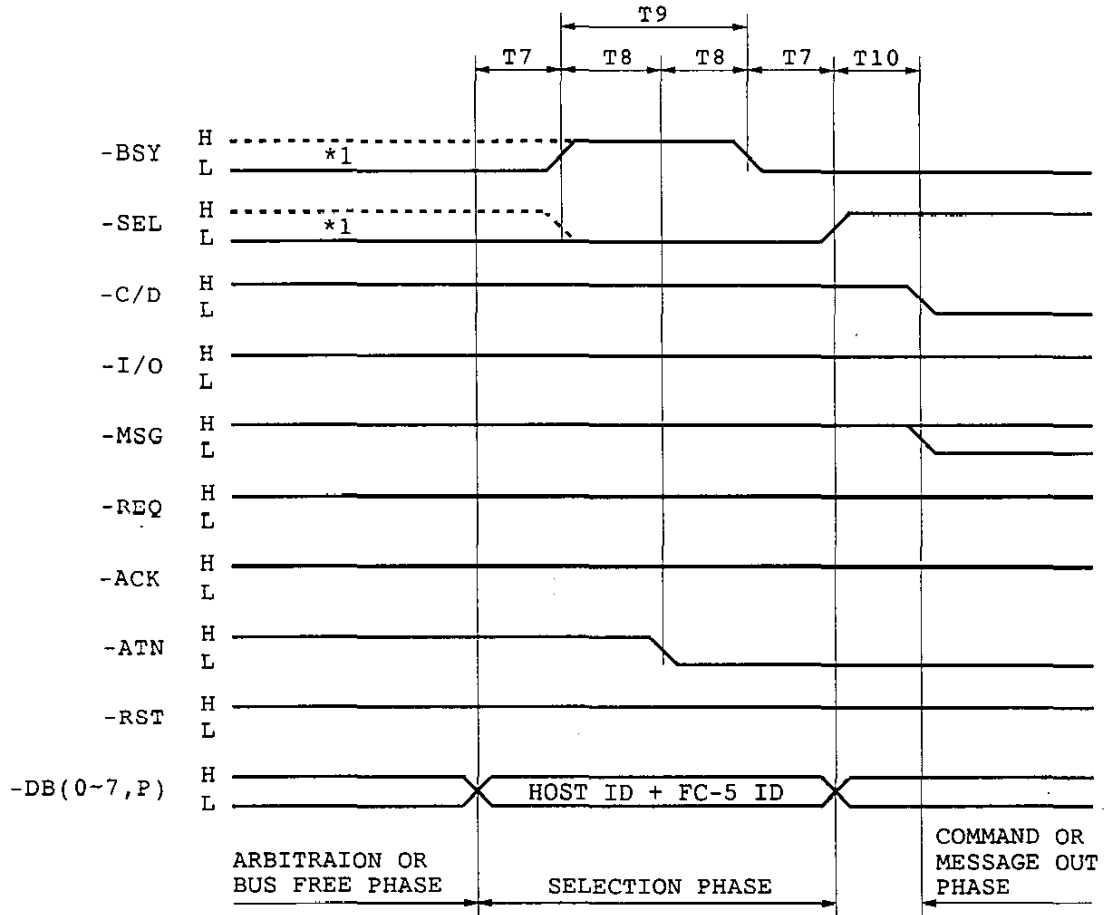

Symbol	Description of symbol	MIN.	TYP.	MAX.	Unit
T7	(DESKEW DELAY) × 2	90			ns
T8		0			ns
T9	BUS SETTLE DELAY	0.4		200	μs
T10		25			μs

*2

Notes: 1. Broken line *1 indicates the case in which the phase changes from BUS FREE phase (without ARBITRATION).

2. MAX. on *2 indicates a selection abort time.

(Fig.10-10) SELECTION phase timing

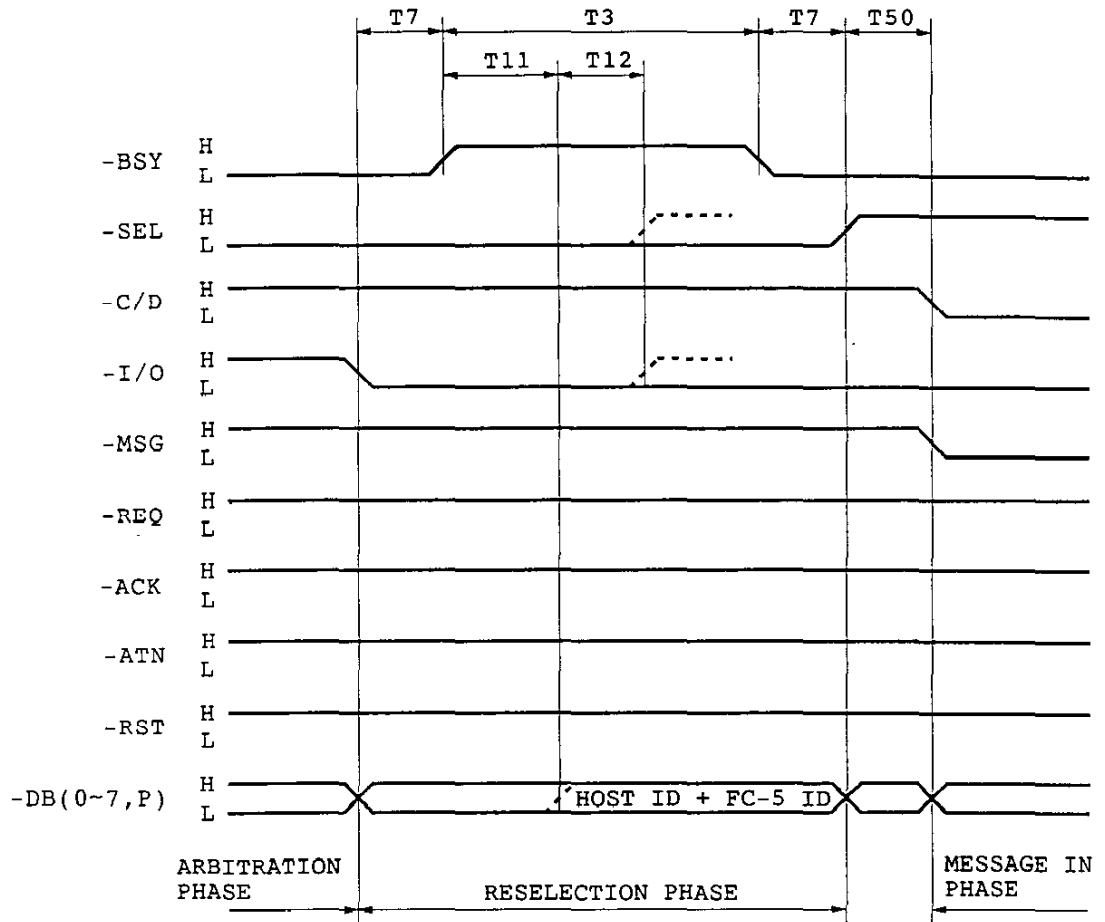

Symbol	Description of symbol	MIN.	TYP.	MAX.	Unit
T3	BUS SETTLE DELAY or SELECTION TIMEOUT	400ns		200 μ s	
T7	(DESKEW DELAY) \times 2	90			ns
T50		65			μ s
T11	SELECTION TIMEOUT	250			ms
T12	SELECTION ABORT TIME + (DESKEW DELAY) \times 2	200.9			μ s

Note: T11, T12 and the broken line indicate the case in which there is no -BSY response from the host (timeout).

(Fig.10-11) RESELECTION phase timing

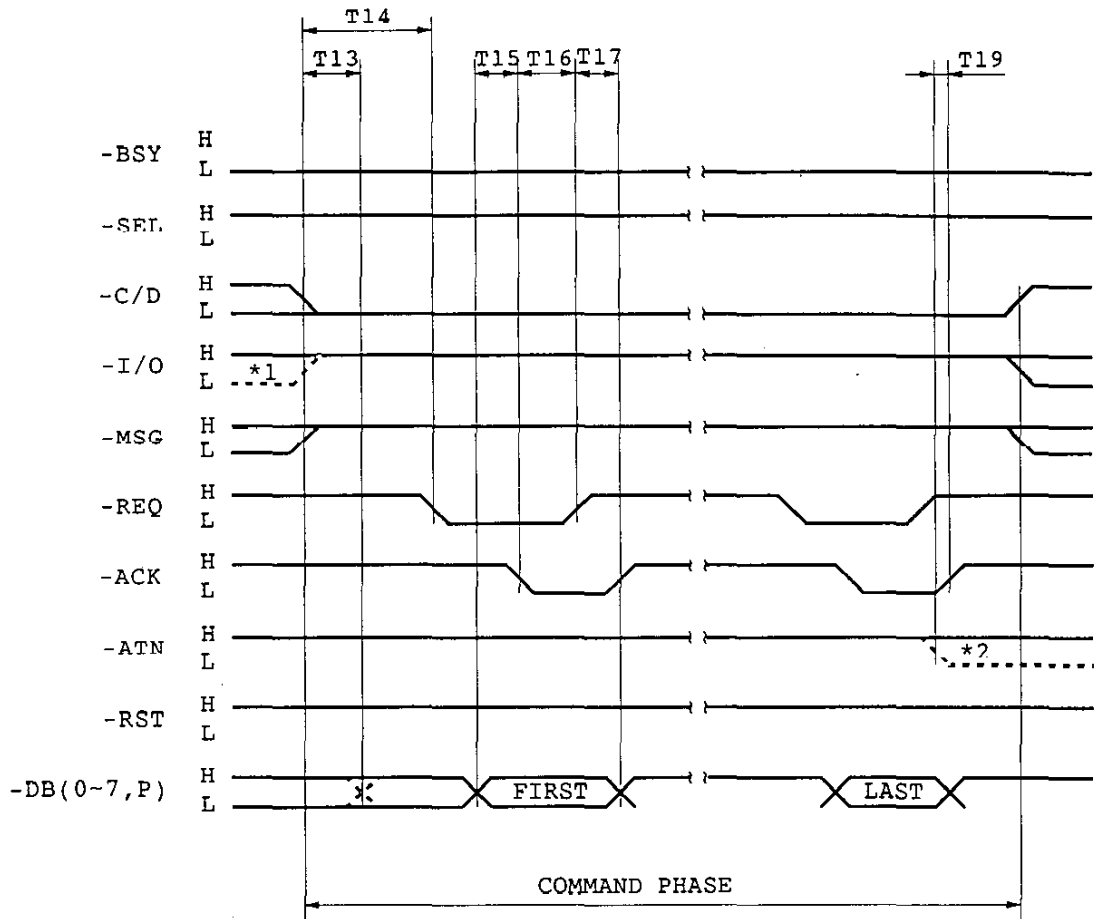

Symbol	Description of symbol	MIN.	TYP.	MAX.	Unit
T13	DESKEW DELAY			45	ns
T14	BUS SETTLE DELAY + DATA RELEASE DELAY	800			ns
T15	DESKEW DELAY + CABLE SKEW	55			ns
T16		0			ns
T17		0			ns
T19		0			ns

- Notes: 1. For the broken line *1, the FC-5 releases the data bus at the timing of T13.
2. The broken line *2 indicates the timing at which the host transmits the -ATN signal in this phase.

(Fig.10-12) COMMAND phase timing

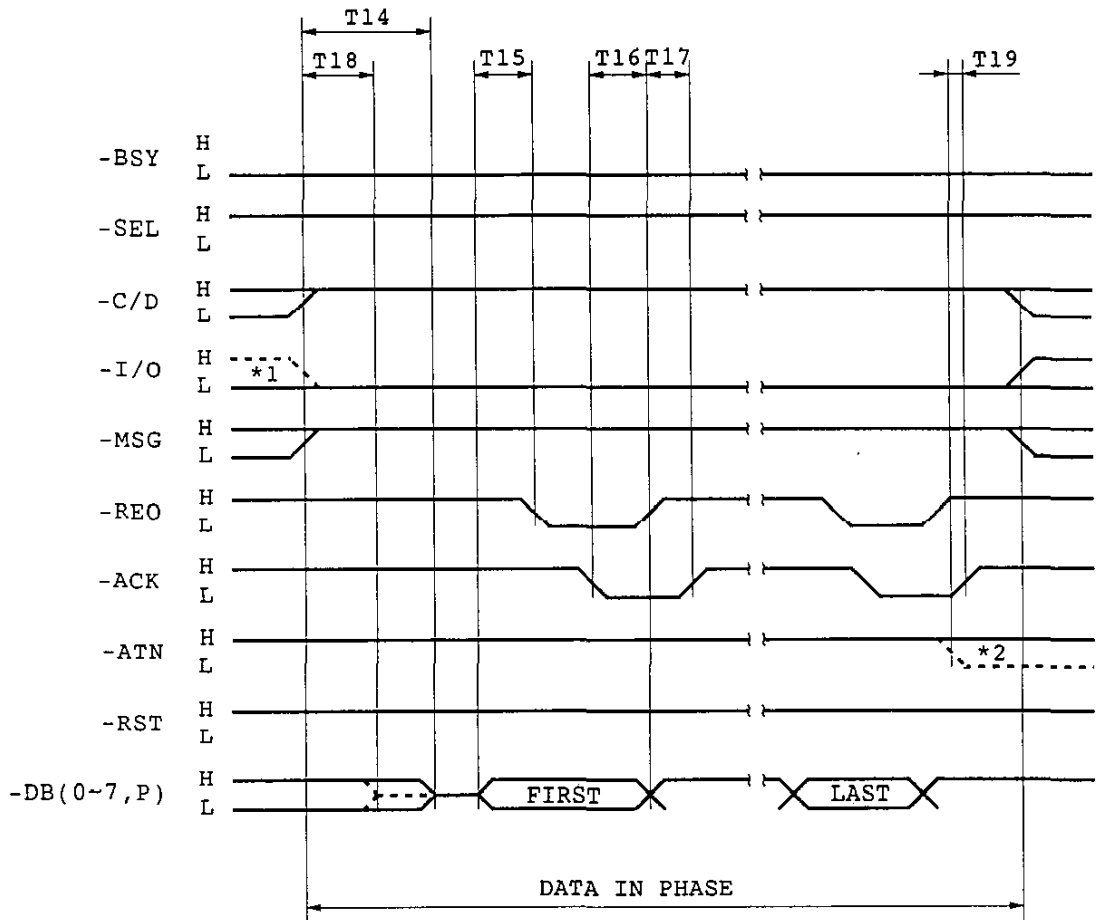

Symbol	Description of symbol	MIN.	TYP.	MAX.	Unit
T14	BUS SETTLE DELAY + DATA RELEASE DELAY	800			ns
T15	DESKEW DELAY + CABLE SKEW	55			ns
T16		0	70		ns
T17		0			ns
T18	DATA RELEASE DELAY			400	ns
T19		0			ns

Notes: 1. For the case of the broken line *1, the host must release the data bus at the timing of T18. At this time, the FC-5 drives the data bus after (T18 or T14) + internal processing time.

2. The broken line *2 indicates the timing at which the -ATN signal is transmitted at the end of this phase.

(Fig.10-13) DATA IN phase timing

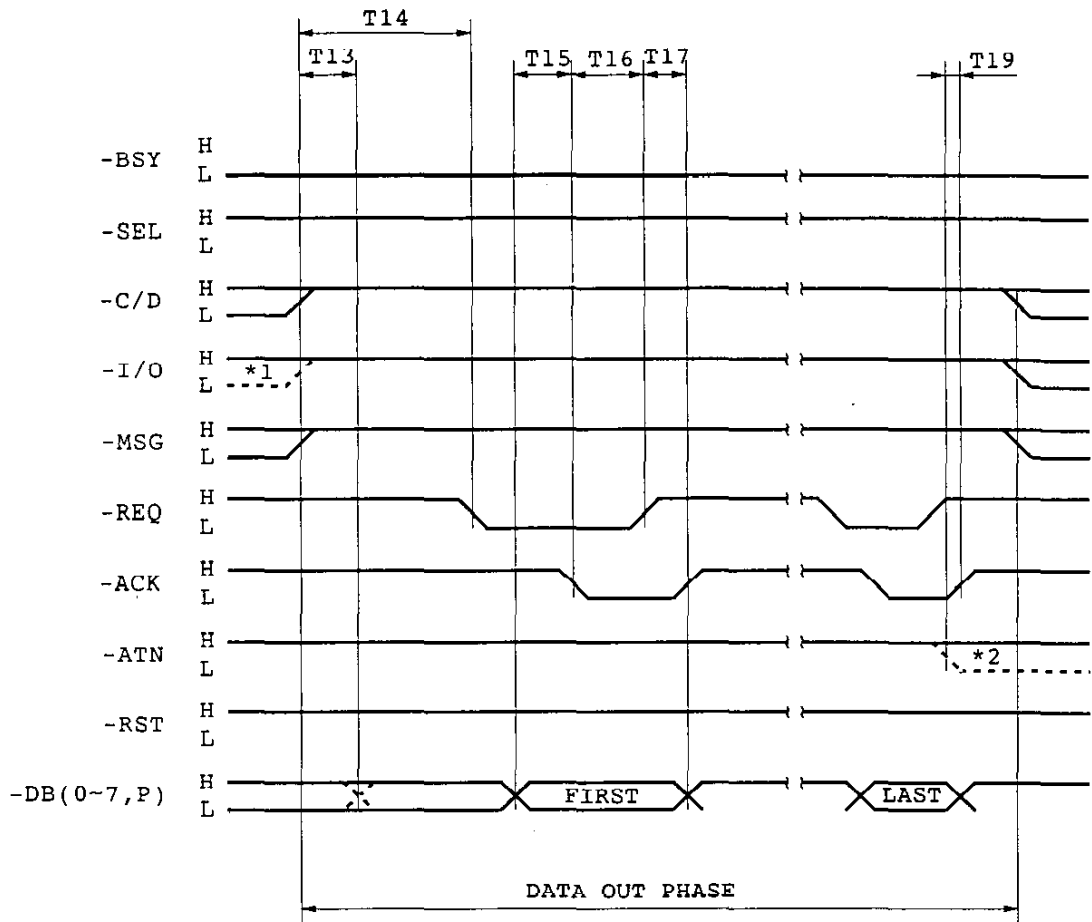

Symbol	Description of symbol	MIN.	TYP.	MAX.	Unit
T13	DESKEW DELAY			45	ns
T14	BUS SETTLE DELAY + DATA RELEASE DELAY	800			ns
T15	DESKEW DELAY + CABLE SKEW	55			ns
T16		0	70		ns
T17		0			ns
T19		0			ns

- Notes: 1. For the case of the broken line *1, the FC-5 releases the data bus at the timing of T13.
2. The broken line *2 indicates the timing at which the -ATN signal is transmitted in this phase.

(Fig.10-14) DATA OUT phase timing

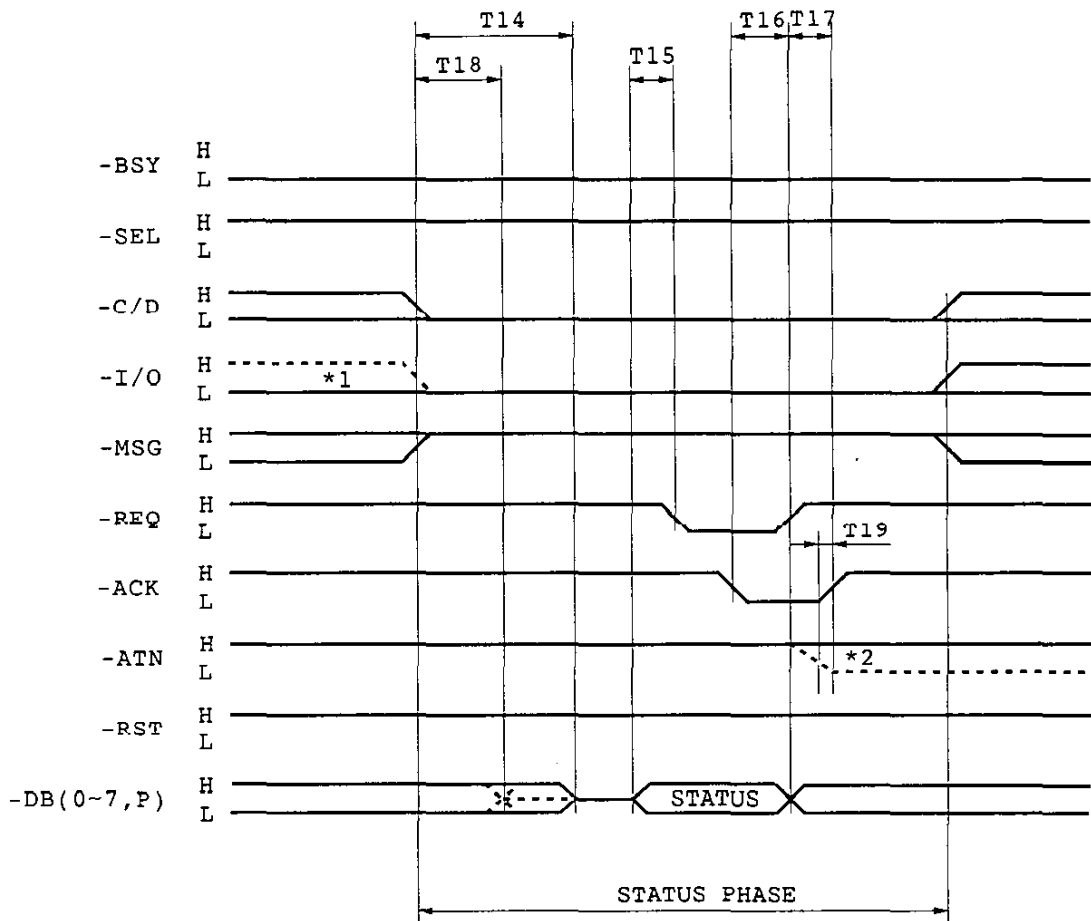

Symbol	Description of symbol	MIN.	TYP.	MAX.	Unit
T14	BUS SETTLE DELAY + DATA RELEASE DELAY	800			ns
T15	DESKEW DELAY + CABLE SKEW	55			ns
T16		0	70		ns
T17		0			ns
T18	DATA RELEASE DELAY			400	ns
T19		0			ns

- Notes: 1. For the case of the broken line *1, the host must release the data bus at the timing of T18. At this time, the FC-5 drives the data bus after (T14 or T18) + internal processing time.
2. The broken line *2 indicates the timing at which the -ATN signal is transmitted at the end of this phase.

(Fig.10-15) STATUS phase timing

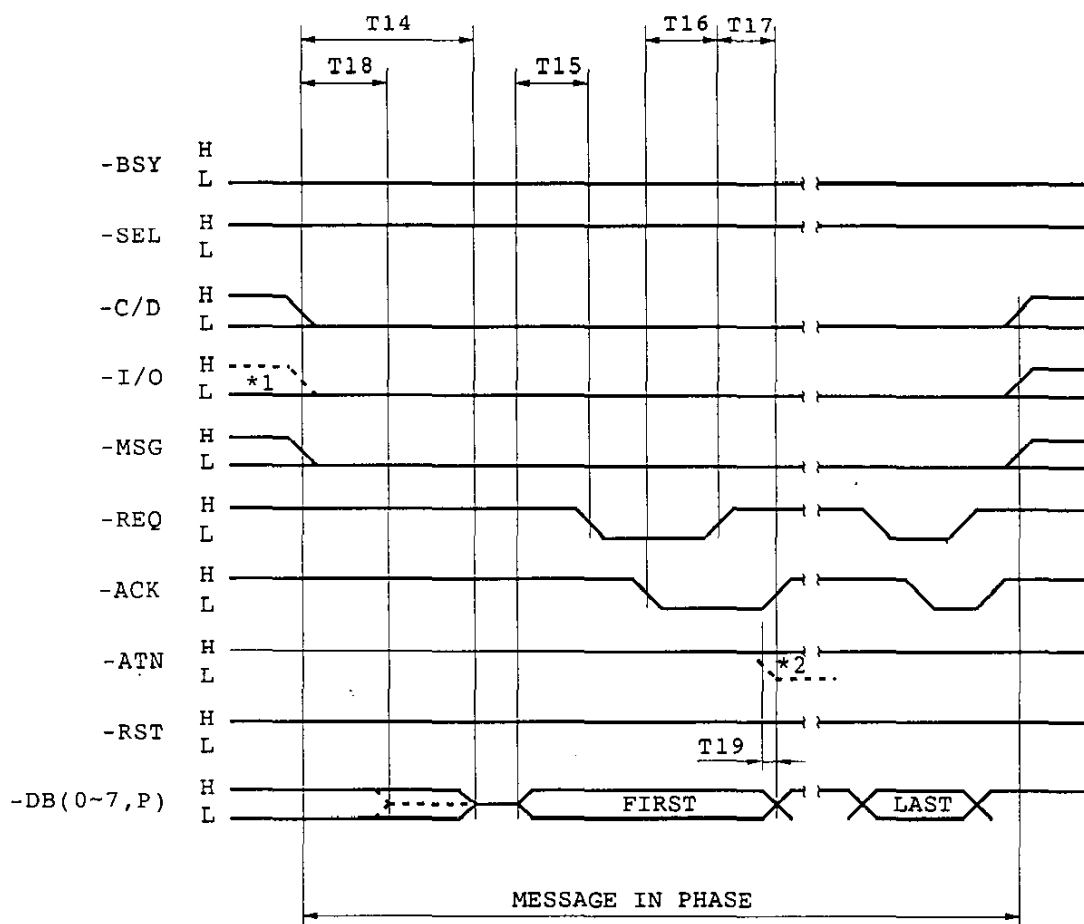

Symbol	Description of symbol	MIN.	TYP.	MAX.	Unit
T14	BUS SETTLE DELAY + DATA RELEASE DELAY	800			ns
T15	DESKEW DELAY + CABLE SKEW	55			ns
T16		0	70		ns
T17		0			ns
T18	DATA RELEASE DELAY			400	ns
T19		0			ns

Notes: 1. For the case of the broken line *1, the host must release the data bus at the timing of T18. At this time, the FC-5 drives the data bus after (T18 or T14) + internal processing time.

2. The broken line *2 indicates the timing at which an -ATN signal is transmitted when the host requests re-transfer of the MESSAGE.

(Fig.10-16) MESSAGE IN phase timing

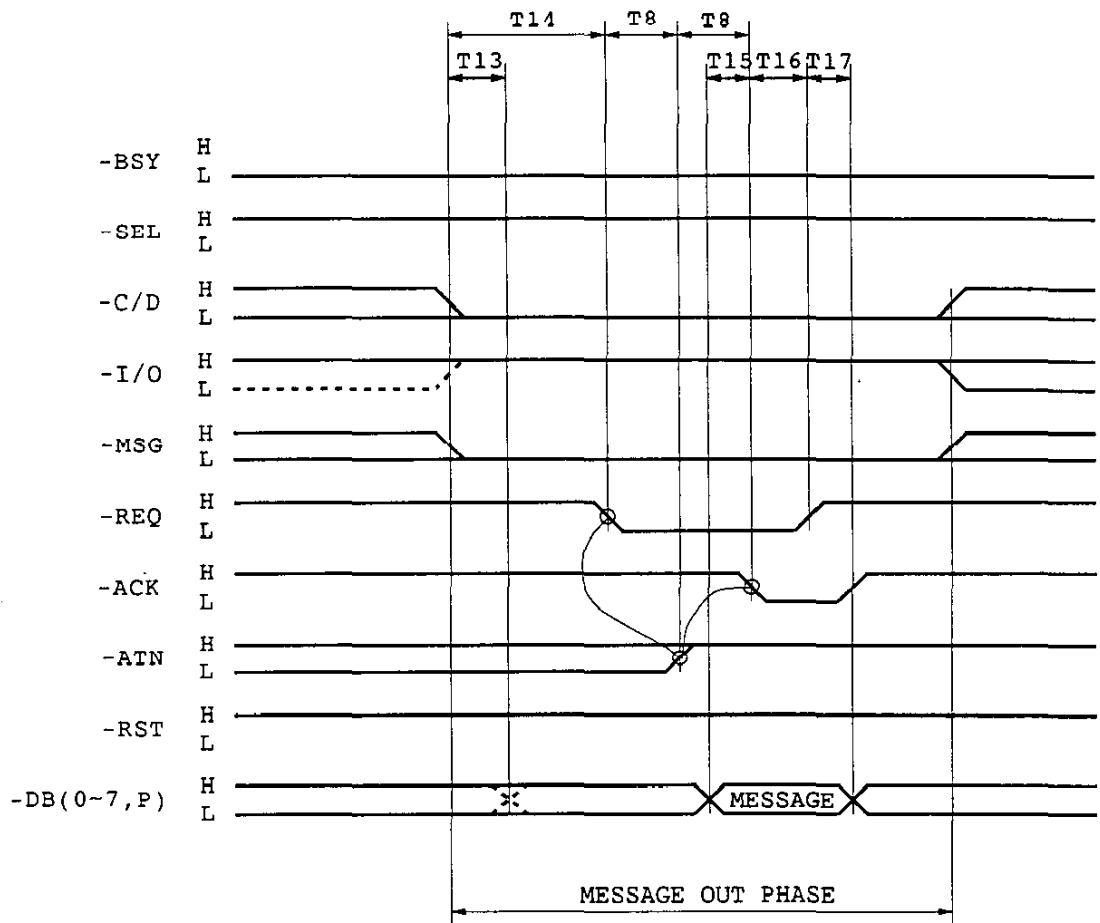

Symbol	Description of symbol	MIN.	TYP.	MAX.	Unit
T8		0			ns
T13	DESKEW DELAY			45	ns
T14	BUS SETTLE DELAY + DATA RELEASE DELAY	800			ns
T15	DESKEW DELAY + CABLE SKEW	55			ns
T16		0	70		ns
T17		0			ns

Note: For the case of the broken line, the FC-5 releases the data bus at the timing of T13.

(Fig.10-17) MESSAGE OUT phase timing

10.6 Control Sequence

10.6.1 Initialized state when the power is switched on or reset

(1) Protection of written data

In the transient period when the +5V power is lower than 3.5V, the SFD is protected against miswriting and miserasing whatever the state of input signals are.

(2) Auto-recalibration

Auto-recalibration is executed (head moves to track 00) immediately after the power-on or reset.

(3) Motor starting state

The moment the unit is bootstrapped, the motor turns ON. However, it stops five seconds later.

(4) Self-diagnosis

The moment the power is switched on or reset, the following items are checked. In the event of an abnormality, HARDWARE ERROR (ADDITIONAL SENSE CODE = A0 ~ A2h) is issued in response to the command given first, terminating in a check condition. If control is continued disregarding this, operation is not guaranteed.

(a) Read/write check of the buffer RAM and I/O port

(b) Specified check of straps

(c) Check of whether or not terminator power is supplied

(5) Mode select state

In the initialized state, the 2MB mode is set.

Operation mode : 2MB

No. of sectors : 18 sectors/track

Block length : 512 bytes/sector

Recording method: MFM

If operation is to be done with the above setting, there is no need to issue a new mode select command.

(6) FC-5 reset sequence after the power is switched ON.

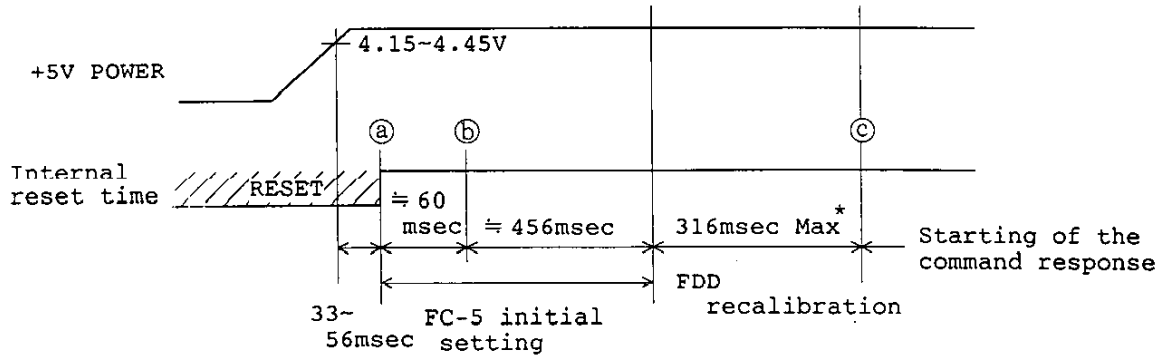

(Fig.10-18) Internal reset time

- Notes:
1. Response is impossible for selection occurring between (a) and (b).
 2. The selection occurring between (b) and (c) shifts phases in the order STATUS (BUSY) → MESSAGE IN (COMMAND COMPLETE) → BUS FREE.
When the RESET signal of SCSI turned to true at (a), the shift is the same.
 3. *: When the head position of the SFD is at track 79.

(7) As sudden power switching applies an undue burden to the SFD, it is desirable to allow 5 seconds or more between switching.

10.6.2 Current consumption profile

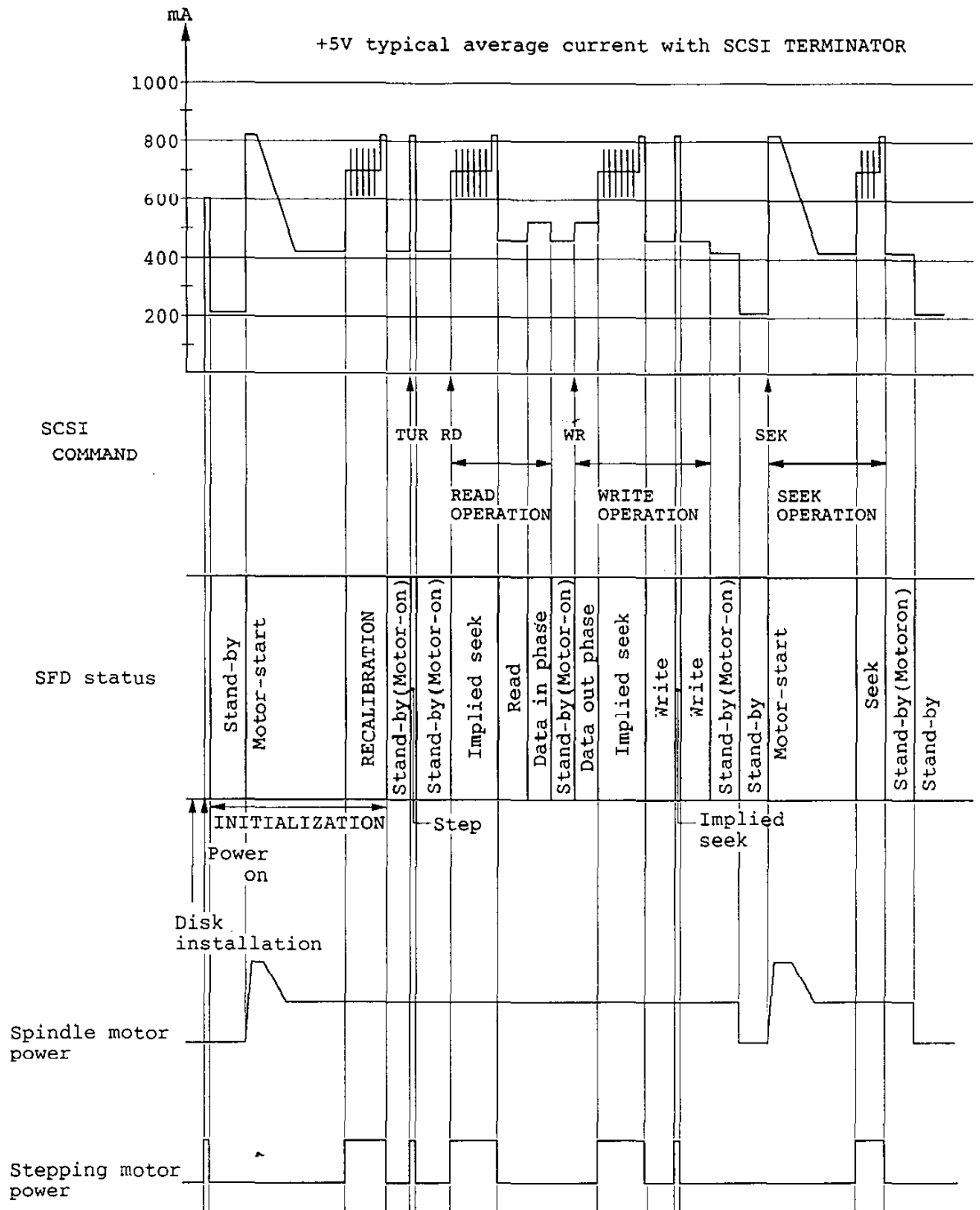

(Fig.10-19) Typical average current profile

10.7 Setting the Mode of the SFD

The mode of this SFD can be selected from among the following two methods.

- (1) The initiator can detect the medium type (DD/HD) now loaded in the SFD.
- (2) Based on the result of (1), the initiator can set the mode according to the type of medium loaded.

The FC-5, by referring to the Page 5 definition of the MODE SELECT data of the MODE SELECT command, controls the FDD density mode setting signal, and sets the three FDD density modes.

FDD interface FDD density mode setting signal	Page 5 definition of MODE SELECT data	Signal direction	1MB	1.6MB	2MB
Pin 11: HD IN signal	Byte 26 low-order 4 bit: DH	FC-5 → FDD	LOW	HIGH	HIGH
Pin 13: 1.6MB IN signal	Byte 27 low-order 4 bit: 3H	FC-5 → FDD	HIGH	LOW	HIGH
Pin 9: HD OUT signal*	Byte 27 high-order 4 bit: FH	FC-5 ← FDD	LOW	HIGH	HIGH

Note * Pin 9 (HD out signal) definition is applied to 02H (Media identification code) of the Medium Type of the HEADER section when executing the MODE SELECT command.
If bits other than 02H are specified to the Medium Type of the HEADER section, Byte 27 high-order 4 bit: 0H (OPEN) can be used.

(Table 10-2) FDD density mode setting input/output signals

- (3) The initiator can recover in even a special case where a disk loaded is written with inherently the wrong density.
For example, read or write of HD medium written in the 1MB mode is possible though reliability is low.

(4) Procedure

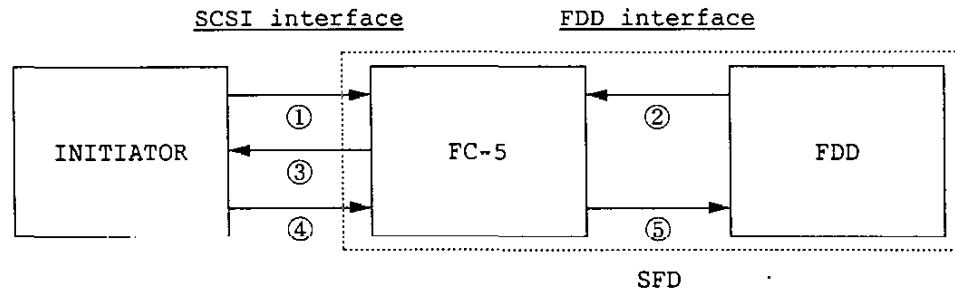

- Procedures:
- ① The initiator executes the MODE SELECT command by making the Medium Type of the HEADER section 02h (Media identification code). (when in POWER ON, SCSI RESET or DISK CHANGE)
 - ② The FC-5 sets the mode inside the FC-5 by referring to the media identification input signal (FDD interface Pin 9: HD OUT signal) from the FDD.
 - ③ The initiator can detect the media loaded in the FDD with the HEADER section of the MODE SENSE data, Medium Type by executing the MODE SENSE command.
HD media: 88h, DD media: 80h
 - ④ The initiator executes the MODE SELECT command before the next write or read action based on the execution result of ③.
 - ⑤ The FC-5 sets the mode of the FDD (FDD interface Pin 11: HD IN signal, Pin 13: 1.6MB IN signal) by the MODE SELECT data of ④.

Note: If the initiator needs not detect the type of medium now loaded in the SFD, ① to ③ above can be omitted.

10.8 Customer Selectable Straps

10.8.1 Straps setting on the FC-5 board

There are straps on the FC-5 board as shown in Fig.10-20 and the state where the shorting bar is inserted is the ON state. Their functions are described below.

Factory-set is follows.

H0, G0, H/G, PAR, ID0 ~ ID2: ON

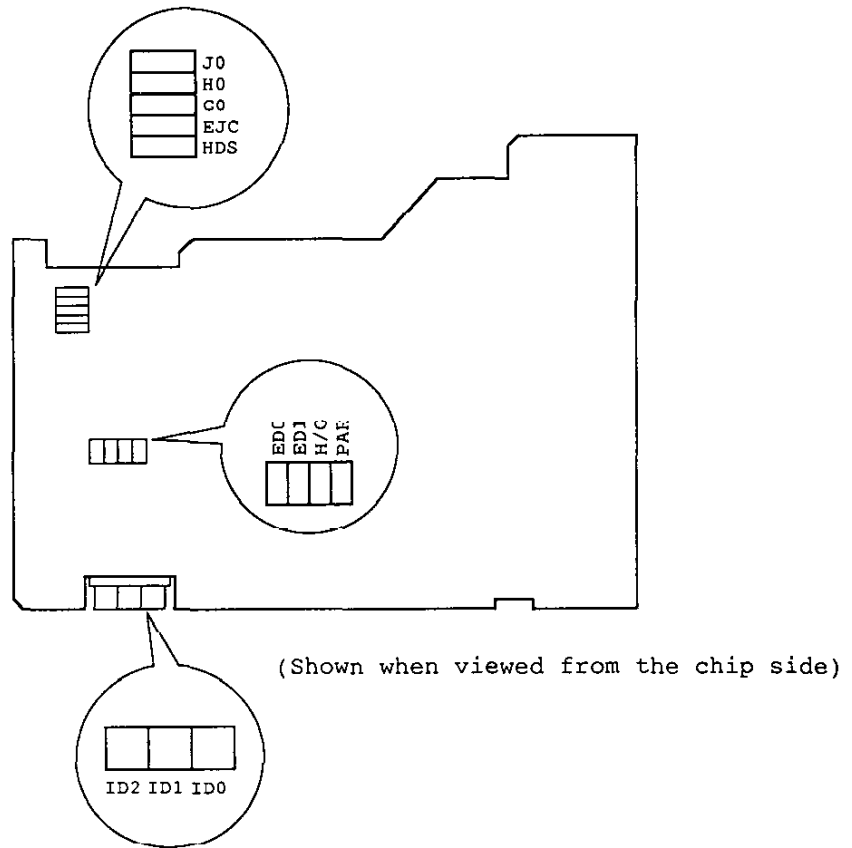

(Fig.10-20) Straps arrangement

(1) ID0/ID1/ID2 straps

Performs SCSI ID setting with "ID0", "ID1", and "ID2" on the PCBA. The relation between "ID0 ~ ID2" settings and the SCSI ID addresses is shown in Table 10-3.

"ID0 ~ ID2" are all factory-set to "ON" (device address = 0).

SCSI ID ADDRESS	ID2	ID1	ID0
0	ON	ON	ON
1	ON	ON	OFF
2	ON	OFF	ON
3	ON	OFF	OFF
4	OFF	ON	ON
5	OFF	ON	OFF
6	OFF	OFF	ON
7	OFF	OFF	OFF

(Table 10-3) SCSI ID setting

(2) PAR strap

"PAR" on the PCBA is the parity strap. When "PAR" is ON, the FC-5 performs parity checking (odd number) of input data (-DB0 ~ -DB7, -DBP). Parity checking does not take place when "PAR" is OFF.

It is factory-set to "ON".

(3) J0/H0/G0 straps

Set the FDD type shown in Table 10-4.

Strap "H0" "G0" are factor-set to ON, and these cannot be changed.

The 1MB mode is valid at all times.

Strap	J0	H0	G0
Mode	4MB mode	2MB mode	1.6MB mode

(Table 10-4) Setting the FDD type

(4) ED0, ED1, H/G straps

These are used to set the signals assigned to pin 11 (HF/GF/HGF type) or pin 21 (JHF/JGF type) in the interface between the FC-5 board and FDD. The H/G straps are factory-set to ON and define the HD IN signal (signal given from the FC-5 board to the FDD to set either the 1MB or 2MB mode) for pin 11.

These straps cannot be changed.

(5) HDS strap

Sets the initial state of the SFD mode auto switching to be valid or invalid according to the type of disk loaded in the SFD.

This is factory-set to OFF, and this cannot be changed.

"HDS": ON Valid
 OFF Invalid

(6) EJC strap

Sets the media ejection function to valid or invalid. The factory setting is OFF.

"EJC": ON Valid
 OFF Invalid

Note: To make this function valid, the eject mechanism must be supported.